

Vehicle lighting manufacturer



www.fristom.com

FT-161 LED



1200
lm

INTERIOR lighting LAMP

FT-161 LED

Series of modern interior **LED** type lamps in a round version has become widely used in the energy-saving electrical installations and also in the widely understood automotive industry such as: cabin lights, load beds, horse trailers and caravans. The main advantages of this lamp are extremely high light emission with a natural. Due to its compact size, shock resistance, easy installation and waterproofness the lamp is very appreciated in motorboat industry.

Mounting by means of a self-drilling screw (included).

Technical specification:

- Supply voltage: **12 – 36V DC**
- Polarization is not optimal:
(+) – black wire; (-) – white wire
- Power consumption: **12V/24V = 1,0A/0,5A**
- Power consumption (rated power): **12V/24V = 12 Watt**
- Effective (measured) light beam: **1200 lm**
- Operating temperature: **-40°C to +55°C**
- Color temperature: **white, neutral; 4000K**

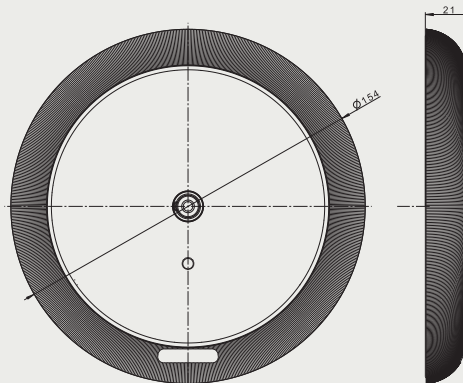
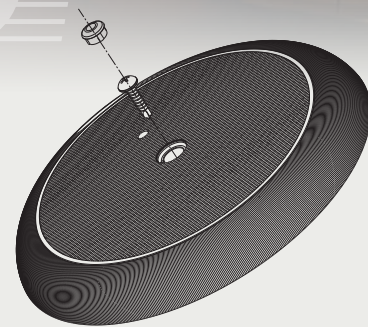

... all you need is light

BIURO:
FRISTOM
Spółka z ograniczoną odpowiedzialnością i Sp. K.
ul. Grunwaldzka 207A
POLAND, 85-451 Bydgoszcz

EXPORT:
mobile +48 609 909 456
bstaniaszek@fristom.com.pl
mobile +48 731 088 883
wtomczak@fristom.com.pl
mobile +48 607 843 275
rcardona@fristom.com.pl